

OPG4250

4.25 Gbps Electrical & Optical Data/Pattern Generator

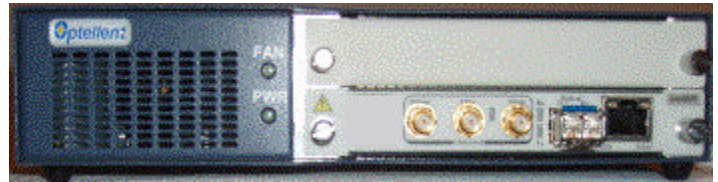

Overview

The OPTELLENT OPG4250 is a cost-effective easy-to-use electrical and optical data pattern generator for testing Fibre Channel (FC) devices, components, modules and systems in R&D and manufacturing environments as well as field installations of Storage Area Networks (SANs). OPB4250 supports 4GFC, 2GFC and 1GFC. The OPB4250 tester is also ideal for Gigabit Ethernet and Infiniband (2.5G) testing. The OPG4250 incorporates an internal reference clock, a pseudo-random bit sequence (PRBS) source, and an RS-232 or USB interface in one compact module that provides both electrical and optical outputs at data rates up to 4.25 Gbps. Additionally, the OPG4250 is offered with multiple PRBS outputs, popular stress patterns, and user-defined patterns. The OPG4250 comes with a standard 2-year warranty.

An intuitive Graphical User Interface enables easy point-and-click operation. Software drivers are available for incorporating the OPG4250 into test automation suites using programs like LabVIEW, VisualBASIC, HP VEE.

Applications

- ▶ Testing of optical transceivers, transponders, linecards, and subsystems at 1x, 2x and 4 x Fibre Channel (FC), Gigabit Ethernet and Infiniband
- ▶ Testing of opto-electronic components and devices (TOSA, ROSA, lasers, etc...)
- ▶ Testing of Gb/s ICs, serial bus, high-speed backplane design, subsystems, and systems
- ▶ Production and compliance testing (EMI, EMC)
- ▶ Installation testing and troubleshooting of Storage Area Networks (SANs)

Key Features

- ▶ Electrical and Optical Outputs
- ▶ Built-in Reference Clock
- ▶ Multiple PRBS Patterns: 2^7-1 , $2^{23}-1$, $2^{31}-1$
- ▶ Stress Patterns (K28.5, CJPAT, CRPAT, CRTPAT)
- ▶ User-defined Patterns
- ▶ Intuitive GUI
- ▶ Automated Test Report
- ▶ Easy-to-Use, Compact and Cost-Efficient
- ▶ 2-year Warranty

Preset Data Rates

Standard Rates	Data Rate
Fibre Channel (1GFC)	1.0625 Gb/s
Gigabit Ethernet	1.25 Gb/s
2 X Fibre Channel (2GFC)	2.125 Gb/s
Infiniband	2.5 Gb/s
4 X Fibre Channel (4GFC)	4.25 Gb/s

Additional Preset Data Rates can be requested (See Ordering Info).

Pattern Generator

Parameter	Min	Typ	Max	Units
Data Output (Electrical)				
Output Type	Differential			
Output Format	NRZ			
Termination	AC-Coupled			
Data Patterns	<ul style="list-style-type: none"> • PRBS: 2⁷-1, 2²³-1; 2³¹-1 101010...pattern • Stress Patterns: K28.5, CJPAT, CRPAT, CRTPAT (Optional) • User-defined Pattern: 128 bits to 500 bits (Optional) 			
Data Rates	<ul style="list-style-type: none"> • Preset: Fibre Channel (1.06 Gbps); Gigabit Ethernet (1.25 Gbps); 2G Fibre Channel (2.125 Gbps); Infiniband (2.5Gb/s); 4G Fibre Channel (4.25 Gbps); • Custom Preset: Special Data rates requested by customers (Optional) 			
Data Rate Range	1.06		4.25	Gbps
Frequency Accuracy			± 50	ppm
Data Output Amplitude (Differential) ⁽¹⁾				
Fixed (Standard)		1600		mV _{p-p}
Variable Output Amplitude (Option)	300		1800	mV _{p-p}
Data Rise/Fall Time, (20 – 80%) ⁽¹⁾		70		ps
Data Output RMS Jitter ⁽¹⁾			5	ps
Connector	SMA Female (50Ω Nominal)			
Data Output (Optical)				
Interface	SFP housing provided as a standard feature MSA-Compliant SFP Transceiver (Optional)			
Wavelength	850nm, 1310nm, 1550nm			
Fiber Type	Multimode and Single Mode Fiber			
Optical Connector	LC			
Clock Output				
Output Type	Single-Ended			
Termination	AC- Coupled			
Output Amplitude (peak-to-peak, S.E.)	200			mV _{p-p}
Connector	SMA Female (50Ω Nominal)			
Trigger Output				
Output Amplitude	400			mV _{p-p}
Output Type	Single-ended, AC-coupled			
Connector	SMA Female (50Ω Nominal)			

(1) Measurements based on PRBS²⁷-1 data at 4.25 Gbps

System & General Specifications

PARAMETER	MIN	MAX	UNIT
Chassis Electrical Voltage	100	240	VAC
Current Drain at Normal Voltage		1.4	A
Operating Temperature Range	5	45	°C
Storage Temperature Range	-40	70	°C
Dimensions (L x W x H)	273x216x45 10.75x8.5x1.75		mm ³ inch ³
Optical Interface	Standard SFP housing		
PC Interface	RS232/USB		
Standard Warranty	2 years		

Software

The Optellent OPG4250 software runs on Windows 98/2000/NT/XP and VISTA over USB or RS-232 serial interface via an RJ-45 Connector provided on the front panel.

Software drivers are available for incorporating the Data/Pattern generator into test automation suites using programs like C++, LabVIEW, VisualBASIC, and HP VEE.

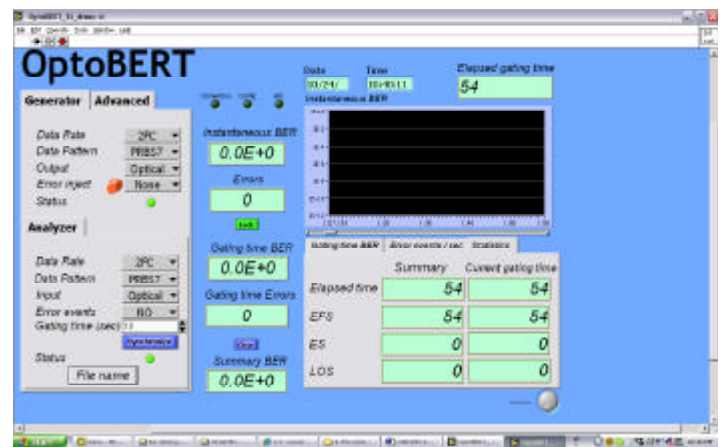

Testing with the OPG4250

Example: Eye quality measurement setup of a DUT having electrical input (i.e., laser, IC, etc...) and a DUT having optical input (i.e., an optical receiver) using the OPG4250

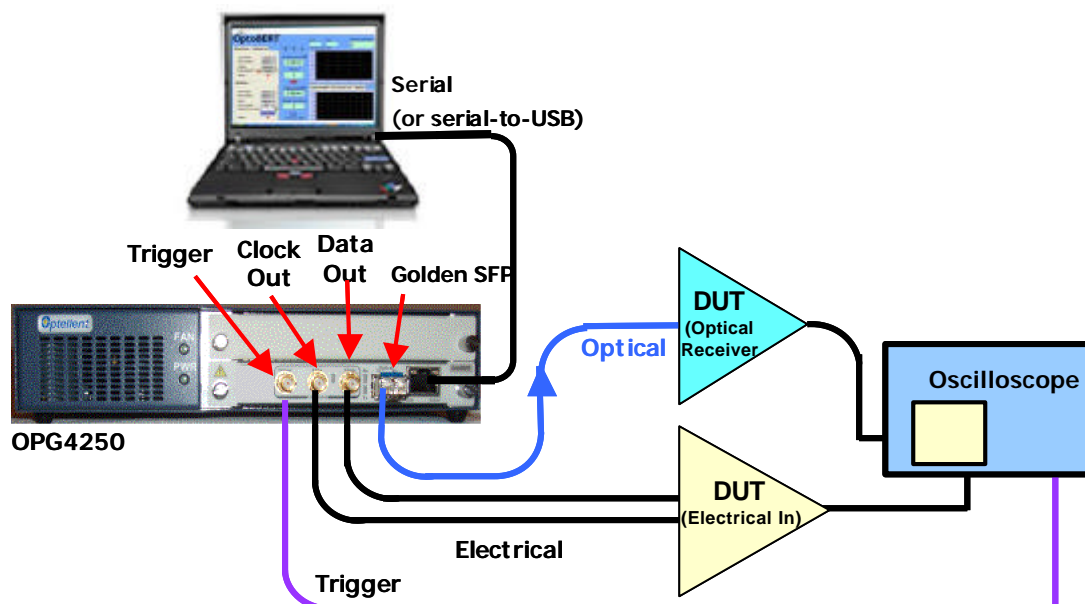

Ordering Information

OPG4250-X-X-X-X

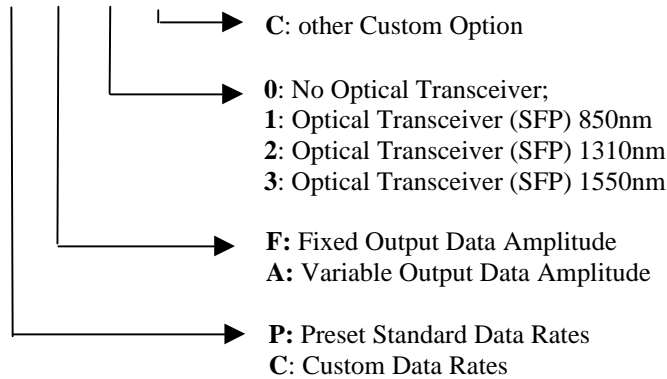

Accessories Included

- User Software
- User Manual
- Power cord
- PC Interface cable

Example: OPG4250-P-F-0: 4.25G Data/Pattern Generator, Preset data rates, Fixed Output Data Amplitude, no transceiver.

Accessories & Services for OPG4250

Part Number	Description
OPZ1015	Serial-to-USB Converter
OPZ2004	Additional 1 year Warranty
OPZ3014	Calibration Service

Related Products

Model Number	Description
OPB4250	4.25 Gb/s OptoBERT (Optical & Electrical BERT)
OPB1250	1.25 Gb/s OptoBERT (Optical & Electrical BERT)
OPG1250	1.25 Gb/s Data/Pattern Generator
OPB3200	3.2 Gb/s OptoBERT (Optical & Electrical BERT)
OPG3200	3.2 Gb/s Data/Pattern Generator
OPBX110	10 Gb/s OptoBERT (Optical & Electrical BERT)
OPGX110	10 Gb/s Data/Pattern Generator

Ordering Contact

For additional information or to order:

Tel: +1.408.230-1329

Fax: +1.408.228.8976

e-mail: sales@optellent.com

Website: www.optellent.com